

A Framework for Understanding: Deriving the Radar Range Equation

$$R_{\max}^4 = \frac{P_t G^2 \lambda^2 \sigma}{k T_0 B_n F_n (S/N) (4\pi)^3}$$



Current Trends and Technologies in Radar

For engineers and scientists, the names behind the earliest experiments in electromagnetism are part of our everyday conversations: Heinrich Hertz, James Clerk Maxwell and Nikola Tesla. If we fast forward from their work in the late 19th and early 20th centuries to radar systems in the 21st century, the fundamental concept—*metallic objects reflect radio waves*—has evolved into a variety of technologies that meet specific needs in terms of performance, cost, size, and capability. These are pushed to the limits in military applications: detecting, ranging, tracking, evading, and jamming.

As in commercial electronics and communications, the evolution from purely analog designs to hybrid analog/digital designs continues to drive advances in capability and performance. In radar systems, frequencies keep reaching higher and signals are becoming increasingly agile. Signal formats and modulation schemes—pulsed and otherwise—continue to become more complex, and this demands wider bandwidth.

Advanced digital signal processing (DSP) techniques are being used to disguise system operation and thereby avoid jamming. Architectures such as active electronically steered arrays (AESA) rely on advanced materials such as gallium nitride (GaN) to implement phased-array antennas that provide greater performance in beamforming and beamsteering.

The most extreme example is a phased-array radar that has thousands of transmit/receive (T/R) modules operating in tandem. These often rely on a variety of sophisticated techniques to improve performance: sidelobe nulling, staggered pulse-repetition interval (PRI), frequency agility, real-time waveform optimization, wideband chirps, and target-recognition capability.

Within the operating environment, the range of complexities may include ground clutter, sea clutter, jamming, interference, wireless communication signals, and other forms of electromagnetic noise. It may also include multiple targets, many of which utilize materials and technologies that present a reduced radar cross section (RCS).

All these modern complexities rely on a mathematical foundation: the radar range equation.

The radar series

This application note is the first in a series that delves into radar systems and the associated measurement challenges and solution. Across the series, our goal is to provide a mix of timeless fundamentals and emerging ideas.

In each note, many of the sidebars highlight solutions—hardware and software—that include future-ready capabilities that can track along with the continuing evolution of radar systems.

Whether you read one, some or all of the notes in the series, we hope you find material—timeless or timely—that is useful in your day-to-day work, be it on new designs or system upgrades.

Deriving the Radar Range Equation

The essence of radar is the ability to scan three-dimensional space and gather information about detected objects, ranging from simple presence to details such as location, speed, direction, shape, and identity. In most implementations, a pulsed-RF or pulsed-microwave signal is generated by the radar system, beamed toward the target in question, and collected by the same antenna that transmitted the signal.

The signal power at the radar receiver is directly proportional to the transmitted power, the antenna gain (or aperture size), and the degree to which a target reflects the radar signal (i.e., its RCS). Perhaps more significantly, it is indirectly proportional to the fourth power of the distance to the target.

This entire process is described by the radar range equation. It incorporates the crucial variables and provides a basis for understanding the measurements that are made to verify and ensure optimal performance.

Our derivation of the range equation starts with a simple spherical scattering model of propagation for a point-source antenna (i.e., an isotropic radiator). Assume, for simplicity, that the antenna is illuminating the interior of an imaginary sphere with equal power density in each unit of surface area (Figure 1). The surface area of a sphere is a function of its radius:

$$A_s = 4\pi R^2$$

A_s = area of a sphere
 R = radius of the sphere

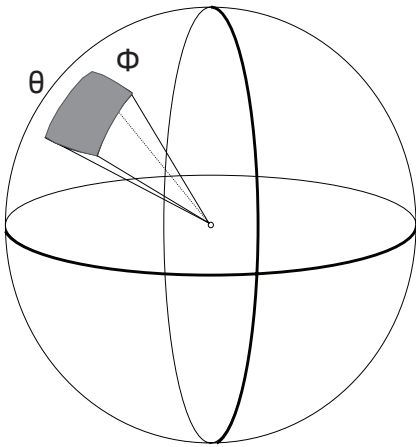

Figure 1. Ideal isotropic antenna radiation produces equal power density in each unit of surface area.

The power density is found by dividing the total transmit power, in watts, by the surface area of the sphere in square meters:

$$\rho = \frac{P_t}{A_s} = \frac{P_t}{4\pi R^2}$$

ρ = power density in watts per square meters
 P_t = total transmitted power in watts

Because radar systems use directive antennas to focus radiated energy onto a target, the equation can be modified to account for the directive gain G of the antenna. This is defined as the ratio of power directed toward the target compared to the power from an ideal isotropic antenna:

$$\rho_T = \frac{P_t G_t}{4\pi R^2}$$

ρ_T = power density directed toward the target from the directive antenna
 G_t = gain of the directive antenna

This equation describes the transmitted power density that strikes the target. Some of that energy will be reflected in various directions and some will be reradiated back to the radar system. The amount of incident power density that is reradiated back to the radar is a function of the RCS or σ of the target. RCS has units of area and is a measure of target size, as seen by the radar (Figure 2).

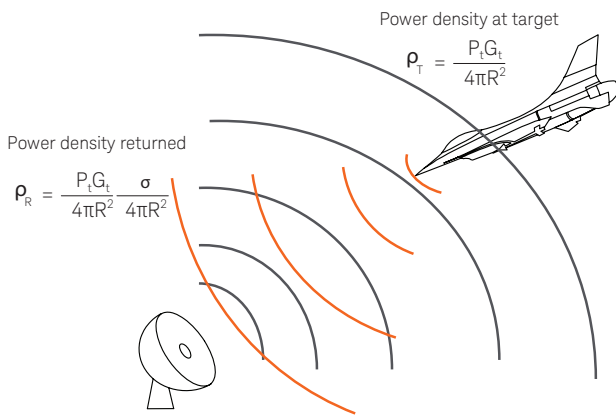

Figure 2. The reflected power density returned to the radar is proportional to the power density of the transmitted signal at the target, and it also affected by the RCS of the target.

With this information, the equation can be expanded to solve for the power density returned to the radar antenna. This is done by multiplying the transmitted power density by the ratio of the RCS and area of the sphere:

$$\rho_R = \frac{P_t G_t}{4\pi R^2} \frac{\sigma}{4\pi R^2}$$

ρ_R = power density returned to the radar, in watts per square meter
 σ = RCS in square meters

Thus, the radar antenna will receive a portion of this signal reflected by the target. This signal power is equal to the return power density at the antenna multiplied by the effective area, A_e of the antenna:

$$S = \frac{P_t G_t \sigma A_e}{(4\pi)^2 R^4}$$

S = signal power received at the receiver in watts
 P_t = transmitted power in watts
 G_t = gain of transmit antenna (ratio)
 σ = RCS in square meters
 R = radius or distance to the target in meters
 A_e = effective area of the receive antenna square meters

Antenna theory allows us to relate the gain of an antenna to its effective area as follows:

$$A_e = \frac{G_r \lambda^2}{4\pi}$$

G_r = gain of the receive antenna
 λ = wavelength of the radar signal in meters

The equation for the received signal power can now be simplified. Note that for a monostatic radar the antenna gain G_t and G_r are equivalent. This is assumed to be the case for this derivation:

$$S = \frac{P_t G_t G_r \lambda^2 \sigma}{(4\pi)^2 R^4 4\pi}$$

S = signal power received at the receiver in watts
 P_t = transmitted power in watts
 G = antenna gain (assume same antenna for transmit and receive)
 λ = wavelength of the radar signal in meters
 σ = RCS of the target in square meters
 R = radius or distance to the target in meters

$$\rightarrow S = \frac{P_t G^2 \lambda^2 \sigma}{(4\pi)^3 R^4}$$

Now that the signal power at the receiver is known, the next step is to analyze how the receiver will process the signal and extract information. The primary factor limiting the receiver is noise and the resulting signal-to-noise (S/N) ratio.

The theoretical limit of the noise power at the input of the receiver is described as Johnson noise or thermal noise. It is a result of the random motion of electrons and is proportional to temperature:

$$N = kTB_n$$

N = noise power in watts
 k = Boltzmann's constant (1.38×10^{-23} J/K)
 T = temperature in Kelvin
 B_n = system noise bandwidth

At a room temperature of 290 K, the available noise power at the input of the receiver is 4×10^{-21} W/Hz, -203.98 dBW/Hz, or -173.98 dBm/Hz. The available noise power at the output of the receiver will always be higher than predicted by the above equation due to noise generated within the receiver.¹ From this, the output noise will be equal to the ideal noise power multiplied by the noise factor and gain of the receiver:

$$N_o = GF_n kTB$$

N_o = total receiver noise
 G = gain of the receiver
 F_n = noise factor

The gain of the receiver can be rewritten as the ratio of the signal output of the receiver to the signal input ($G = S_o/S_i$). Solving for the noise factor F_n yields the following equation:

$$F_n = \frac{S_i / N_i}{S_o / N_o} \quad \text{Where } N_i = kTB$$

1. In addition to noise factor, other limiting factors include oscillator noise (such as phase noise or AM noise), spurious signals ("spurs"), residuals, and images. Whether these signals are noise-like or not, they will impact the receiver's ability to process the received signals. For simplicity, these factors are not part of this derivation. Please note, though, that phase noise and spurs are important factors that can affect radar performance and are therefore included as part of the measurement discussion presented in a later note in this series.

By definition, the noise factor is the ratio of the S/N in to the S/N out. The equation can then be rewritten in a different form, and again $G = S_o/S_i$:

$$F_n = \frac{N_o}{kT_oB_nG}$$

N_o = total receiver noise
 G = gain of the receiver
 S_o = receiver output signal
 S_i = receiver input signal
 T_o = room temperature
 k = Boltzmann's constant
 B_n = receiver noise bandwidth

Because noise factor describes the degradation of signal-to-noise as the signal passes through the system, the minimum detectable signal (MDS) at the input can be determined. It corresponds to a minimum output S/N ratio with an input noise power of kTB , and S_i approaches S_{min} when the minimum S_o/N_o condition is met:

$$S_{min} = kT_oB_nF_n \left(\frac{S_o}{N_o} \right)_{min}$$

S_{min} = minimum power required at input of the receiver
 F_n = noise factor
 $(S_o/N_o)_{min}$ = minimum ratio required by the receiver processor to detect the signal

Now that the minimum signal level required to overcome system noise is defined, the maximum range of the radar can be calculated by equating the MDS (S_{min}) to the signal level reflected from the target at maximum range. Setting S_{min} equal to the earlier equation for S yields the following:

$$S_{min} = kT_oB_nF_n \left(\frac{S_o}{N_o} \right)_{min} = \frac{P_t G^2 \lambda^2 \sigma}{(4\pi)^3 R_{max}^4}$$

Rearranging this equation, we can solve for the maximum range of the radar:

$$R_{max}^4 = \frac{P_t G^2 \lambda^2 \sigma}{kT_oB_nF_n(S/N) (4\pi)^3}$$

P_t = transmitted power in watts
 G = antenna gain (assume same antenna for transmit and receive)
 λ = wavelength of radar signal in meters
 σ = RCS of target in square meters
 k = Boltzmann's constant
 T = room temperature in Kelvin
 B_n = receiver noise bandwidth in hertz
 F_n = noise factor
 S/N = minimum signal-to-noise ratio required by receiver processor to detect the signal

The equation now describes the maximum target range of the radar as a function of transmitter power, antenna gain, target RCS, system noise figure, and minimum S/N ratio. In reality, this is a simplistic model of system performance. Many other factors also affect performance, and this includes modifications to the assumptions made to derive this equation.

Two additional items that should be considered are system losses and pulse integration that may be applied during signal processing. Losses in the system will be found both in the transmit path (L_t) and in the receive path (L_r). In a classical pulsed-radar application, we could assume that multiple pulses would be received from a given target for each position of the radar antenna and therefore could be integrated together to improve system performance.¹ Because this integration may not be ideal, we will use an integration efficiency term $E_i(n)$, based on the number of pulses integrated, to describe integration improvement.

Including these terms yields the following equation:

$$R_{\max}^4 = \frac{P_t G^2 \lambda^2 \sigma E_i(n)}{kTB_n F_n (S/N) (4\pi)^3 L_t L_r}$$

L_t = losses in the transmitter path
 L_r = losses in the receive path
 $E_i(n)$ = integration efficiency factor

To simplify the discussion, the entire equation can be converted to log form (dB):

$$40 \text{ Log}(R_{\max}) = P_t + 2G + 20 \text{ Log}\lambda + \sigma + E_i(n) + 204 \text{ dBW/Hz} - 10 \text{ Log}(B_n) - F_n - (S/N) - L_t - L_r - 33 \text{ dB}$$

Where:

- R_{\max} = maximum distance in meters
- P_t = transmit power in dBW
- G = antenna gain in dB
- λ = wavelength of the radar signal in meters
- σ = RCS of target measured in dB_{sm} or dB relative to a square meter
- F_n = noise figure (noise factor converted to dB)
- S/N = minimum signal-to-noise ratio required by receiver processing functions to detect the signal in dB

The 33 dB term comes from $10 \log(4\pi)^3$, which can also be written as $30 \log(4\pi)$, and the 204 dBW/Hz is from Johnson noise at room temperature. The decibel term for RCS (σ) is expressed in dB_{sm} or decibels relative to a one-meter section of a sphere (e.g., one with cross section of a square meter), which is the standard target for RCS measurements. For multiple-antenna radars, the maximum range grows in proportion to the number of elements, assuming equal performance from each one.

1. Because the radar's antenna beam width is greater than zero, we can assume that the radar will dwell on each target for some period of time.

Relating the Range Equation To a System Block Diagram

Figure 3 shows a simplified block diagram of a typical radar system. While it could be much more complicated, the diagram highlights the six essential blocks.

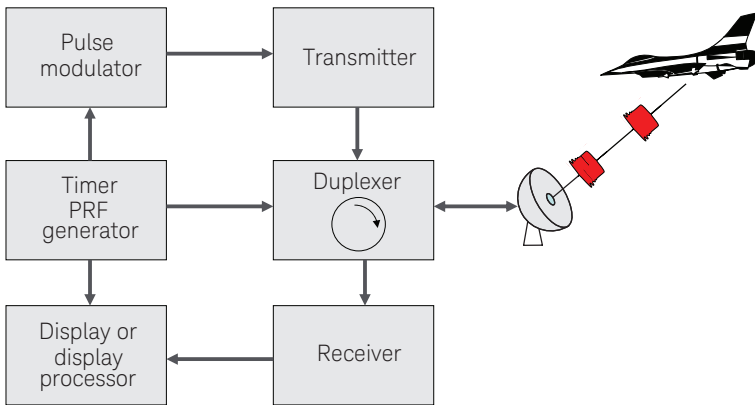

Figure 3. This simplified block diagram highlights the essential elements of a typical radar system.

The master timer or PRF generator is the central block of the system. It time-synchronizes all components of the system through connections to the pulse modulator, duplexer (i.e., transmit/receive switch) and display processor. In addition, connections to the receiver provide gating for front-end protection or timed gain control such as a sensitivity time control (STC).

Figure 4 shows an expanded view of the transmitter and receiver sections of the block diagram. This version shows a hybrid analog/digital design that enables many of the latest techniques. The callouts indicate the location of key variables within the simplified radar equation:

$$40 \text{ Log}(R_{\text{max}}) = P_t + 2G + 20 \text{ Log}\lambda + \sigma + E_i(n) + 204 \text{ dBW/Hz} - 10 \text{ Log}(B_n) - F_n - (S/N) - L_t - L_r - 33 \text{ dB}$$

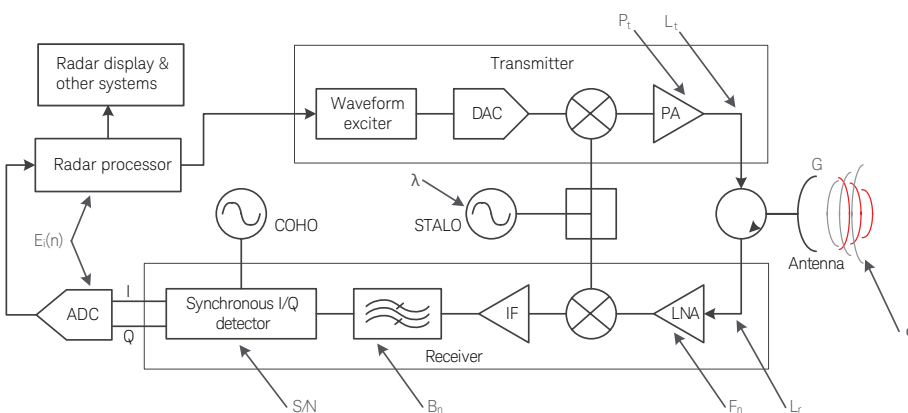

Figure 4. The variables in the radar range equation relate directly to key elements of this expanded block diagram.

Conclusion

Decades after Hertz, Maxwell and Tesla, the fundamental concept still holds: metallic objects reflect radio waves. As derived here, the radar range equation captures the essential variables that define the maximum distance at which a given radar system can detect objects of interest. Because those variables relate directly to the major sections of a radar system block diagram, they provide a powerful framework for understanding, characterizing and verifying the actual performance of any radar system.

Subsequent application notes in this series will focus on four sections of the block diagram: transmitter, receiver, duplexer and antenna. As these blocks are expanded, we will continue to associate the parameters of the range equation with each block or component.

Future notes in the series will also highlight products—hardware and software—that provide capabilities that can track along with the continuing evolution of radar systems.

Related Information

- Application Note: *Radar Measurements*, literature number 5989-7575EN
- Application Note: *New Pulse Analysis Techniques for Radar and EW*, literature number 5992-0782EN
- Application Note: *Using SystemVue's Radar Library to Generate Signals for Radar Design and Verification*, literature number 5990-6919EN
- Application Note: *Radar Development Using Model-Based Engineering*, literature number 5992-0544EN
- Application Note: *Accelerating the Testing of Phased-Array Antennas and Transmit/Receive Modules*, literature number 5992-1171EN
- Webcast: *Precision Validation of Radar System Performance in the Field*
- Brochure: *Multi-Channel Antenna Calibration, Reference Solution*, literature number 5991-4537EN
- Poster: *Radar Fundamentals*
- Poster: *Electronic Warfare Fundamentals*

Learn more at: www.keysight.com

For more information on Keysight Technologies' products, applications or services, please contact your local Keysight office. The complete list is available at: www.keysight.com/find/contactus

